



LEADING THE UK EWI INDUSTRY

INCA Technical Guidance Document 01

Fire Performance Requirements for EWI Systems



June 2023

INCA Technical Guidance Document 01

June 2023

Fire Performance Requirements for EWI Systems

The four geographic regions to which the Building Regulations apply, namely England, Wales, Scotland, and Northern Ireland, each have their own provision for achieving an acceptable standard of fire performance. These specify requirements for the resistance to fire spread over external walls considering the height of the structure, space separation between buildings, position in relation to boundaries, unprotected areas, and the intended use of the structure.

This guidance document was updated to include the amendments to The Building Regulations 2019 (England) incorporating 2020 & 2022 amendments and The Building (Scotland) Regulations 2020 incorporating 2021 & 2022 amendments. It also includes references to The Building Regulations 2006 (Wales) incorporating 2010, 2016, 2020 & 2022 amendments.

Insulated Render and Cladding Association (INCA)

Company Number 03728766 DE73 6WU

Tel: 0330 124 6585 Email: info@inca-ltd.org.uk

Website: www.inca-ltd.org.uk

The Regulations, Standards and other references given in this document are believed to be correct at the time of issue. These documents remain subject to regular review, amendments, and updates. Whilst INCA will endeavour to review the current status of the documents, the reader is advised to check that they are still valid and that they reference the latest versions and Regulations.

© INCA Ltd 2023 all rights reserved

Building Regulations

The Building Regulations in the UK apply to the safe design and construction of new buildings and the refurbishment of existing structures and compliance to all aspects of these Regulations, including fire safety, is a legal requirement. England, Wales, Scotland, and Northern Ireland all have their own guidance documents and within these are dedicated parts relating to all aspects of building fire safety. Each has provision for achieving adequate containment of fire spread over the external envelope of a structure and although the underlying principles are common to all, the requirements and guidance for individual UK regions may differ.

Within the Regulations reference is made to both British (BS) and European (BS EN) fire standards applicable to the surface spread of flame and fire performance on multi-storey buildings. This guide considers fire safety requirements in relation to the regulations and these standards.

At the time of publication of this document, the following documents were current: -

Table 1		
Country	Document	Date of issue
England	Approved Document B England	2019 edition; May 2020 & December 2022 amendments
Scotland	Technical Handbook 2	2022 edition
Wales	Approved Document B Wales	2006 edition incorporating 2010 and 2016 amendments; 29 th January 2020 amendment and June 2022 amendment
Northern Ireland	Technical Booklet E	October 2012 edition & April 2022 amendment AMD 7

In conjunction with this guide, it is important to read the current Regulations and approval documents. This guide is intended as an overview to inform the reader about the fire performance of cladding systems and should not be used to demonstrate compliance to the Regulations.

Legislation

When considering the design of EWI systems the parts of the Regulations relating to the construction of external wall cladding should include specific reference to non-load bearing EWI systems in terms of combustibility, structure height and the intended use of the structure. However, these should never be assessed in isolation and without reference to other related and relevant parts of the Regulations.

With regards to the fire and fire safety requirements for external cladding, the relevant documents and associated clauses are provided below:

England & Wales

The regulations recently incorporated a new building purpose group known as a ‘relevant building.’

- a) a “relevant building” means a building with a storey (not including roof-top plant areas or any storey consisting exclusively of plant rooms) at least 18 metres above ground level and which
 - (i) Contains one or more dwellings;
 - (ii) Contains an institute; or
 - (iii) Contains a room for residential purposes and

- b) ‘above ground level’ in relation to a storey means above ground level when measured from the lowest ground level adjoining the outside of a building to the top of the floor surface of the storey.”

The Approved Documents provides a table of detailing the minimum Euroclassification requirements to EN 13501-1 for the Reaction to Fire performance of the external surface of the wall. This is broken down against the building purpose group taking into consideration the purpose group ‘relevant buildings’, in additional to purpose groups 1 and 2, building height and proximity to the site boundary.

Purpose Groups

Building uses are classified within different purpose groups which represent different levels of hazard. A purpose group can apply to a whole building or a compartment within the building and should relate to the main use of the building or compartment.

Purpose group 1

Table 2		
Title	Group	Purpose for which the building or compartment is intended for
Residential dwelling	1 (a)	Flat
Residential dwelling	1 (b)	Dwellinghouse that contains a habitable storey with a floor level a minimum of 4.5m above ground level up to a maximum of 18m
Residential dwelling	1 (c)	Dwellinghouse that does not contain a habitable storey with a floor level a minimum of 4.5m above ground level

Purpose group 2

Table 3		
Title	Group	Purpose for which the building or compartment is intended for
Residential institutional	2 (a)	Hospital, home, school, or other similar establishment, where people sleep on the premises. The building may be either of the following: <ul style="list-style-type: none"> • Living accommodation for, or accommodation for the treatment, care, or maintenance of either: <ul style="list-style-type: none"> ○ Disabled people with a range of impairments including physical, sensory, and cognitive impairments, or mental health conditions. ○ People under the age of 5 years. • A place of lawful detention.
Residential other	2 (b)	Hotel, boarding house, residential college, hall of residence, hostel or any other residential purpose not described above.

Purpose group 3 is for offices.

Purpose group 4 is for shops and commercial premises.

Purpose group 5 is for assembly and recreation.

Purpose group 6 is for industrial.

Purpose group 7a is for storage or any premises not included in purpose groups 1-6.

Purpose group 7b is for car parks.

The above tables are an outline of the requirements of the Approved Documents and should be checked against the Approved Document for notations.

An overview can be seen in the table below and considered to be the linear route for compliance.

Table 4

Reaction to fire performance of external surface of walls			
Building type	Building height	Less than 1000mm from the relevant boundary	1000mm or more from the relevant boundary
'Relevant buildings' as defined in Regulation 7(4)		Class A2-s1, d0 or better	Class A2-s1, d0 or better
All 'residential' purpose groups (purpose groups 1 and 2)	More than 11m	Class A2-s1, d0 or better	Class A2-s1, d0 or better
	11m or less	Class B3-s3, d2 or better	No provisions
Assembly and recreation	More than 18m	Class B3-s3, d2 or better	From ground level to 18m; class C-s3, d2 or better. From 18m in height and above: class B-s3, d2 or better
	18m or less	Class B3-s3, d2 or better	Up to 10m above ground level: class C-s3, d2 or better; Up to 10m above a roof or any part of the building to which the public have access: class C-s3, d2 or better; From 10m in height and above: no minimum performance.
Any other building	More than 18m	Class b-s3, d2 or better	From ground level to 18m: class C-s3, d2 or better; From 18m in height and above: class B-s3, d2 or better
	18m or less	Class B-s3, d2 or better	No provisions

In addition to the requirements within this table, a building with a storey 18m or more in height any insulation product, filler material (such as the core materials of metal composite panels, sandwich panels and window spandrel panels but including gaskets, sealants, and similar) etc. used in the construction of an external wall should be class A2-s3, d2 or better. This restriction does not apply to masonry cavity wall construction, unless regulation 7(2) applies, as that regulation prevails over all the provisions of this paragraph.

In buildings that include a 'residential' purpose (purpose groups 1 and 2) with a storey 11m or more in height any insulation product, filler material (such as the core materials of metal composite panels, sandwich panels and window spandrel panels but including gaskets, sealants, and similar) etc. used in the construction of an external wall should be class A2-s3, d2 or better. This restriction does not apply to masonry cavity wall construction, unless regulation 7(2) applies, as that regulation prevails over all the provisions of this paragraph.

For non 'relevant buildings' and non-purpose group 1 and 2, the alternative route of compliance is for the external wall, including the EWI system and wall build-up (including substrate), to meet the performance criteria given in BRE report BR 135 using full scale test data from BS 8414-1 or BS 8414-2. This non-linear route may not be acceptable in all local authority regions and guidance should be sought.

The following elements of the façade are exempt from the above classification requirements:

- (a) Cavity trays when used between two leaves of masonry;
- (b) Any part of a roof (other than a part of a roof which falls within paragraph 9iv) of regulation 2(6)) if that part is connected to an external wall;
- (c) Door frames and doors;
- (d) Electrical installations;
- (e) Insulation and waterproofing materials used below ground level;
- (f) Intumescent and fire stopping materials where the inclusion of the materials is necessary to meet the requirements;
- (g) Membranes;
- (h) Seals, gaskets, fixings, sealants, backer rods;
- (i) Thermal break materials where the inclusion of the materials is necessary to meet the thermal building requirements of the Approved Documents; or
- (j) Window frames and doors;
- (k) Fibre optic cables;
- (l) Water proofing and insulation up to 300mm.

Whilst exempt, the above elements must still meet the guidance and minimum performance criteria defined in the Regulations.

Height of the top storey in a building.

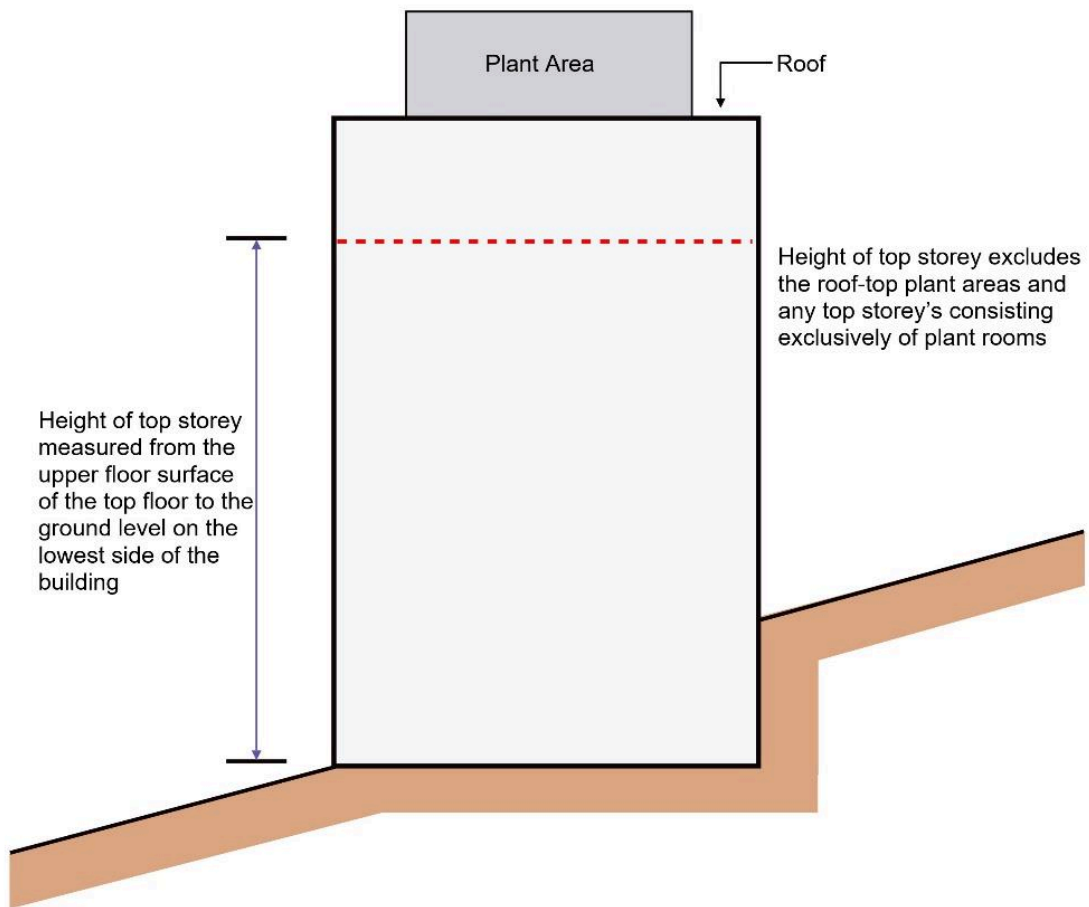

The graphic below shows a summary of the Reaction to Fire classification required for the external wall construction of a building taking into consideration of the distance to boundary, building height and purpose group. It is a visual summary of the table above.

Relevant buildings as defined in Regulation 7

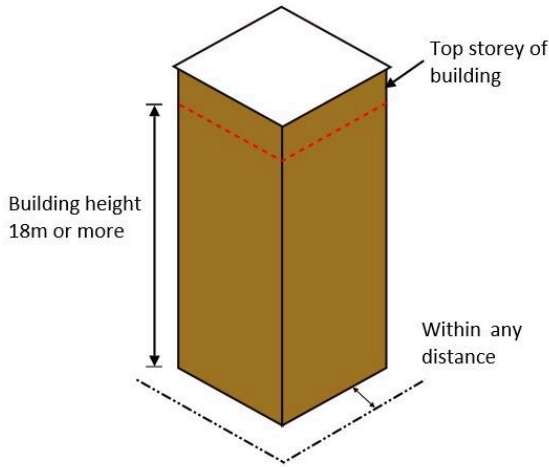

KEY TO EXTERNAL WALL SURFACE CLASSIFICATION

- Relevant boundary
- A2-s1, d0 or better
- B or better
- C or better
- No provision in respect to boundaries indicated

Notes:

- 1 The national classifications do not automatically equate with the equivalent European classifications, therefore, products cannot typically assume a European class unless they have been tested accordingly.
- 2 When a classification includes "s3, d2", this means that there is no limit set for smoke production and/or flaming droplets/particles.

Any other building greater 18m

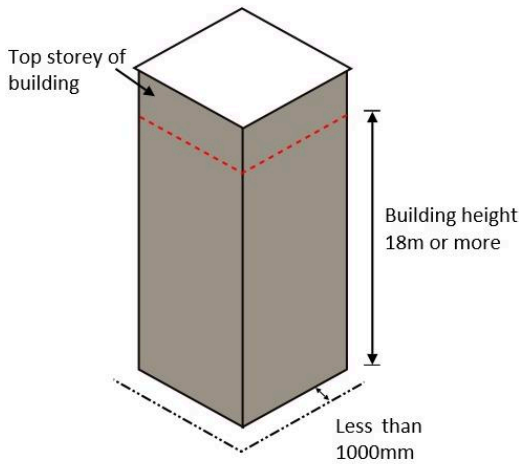

Any other building greater 18m

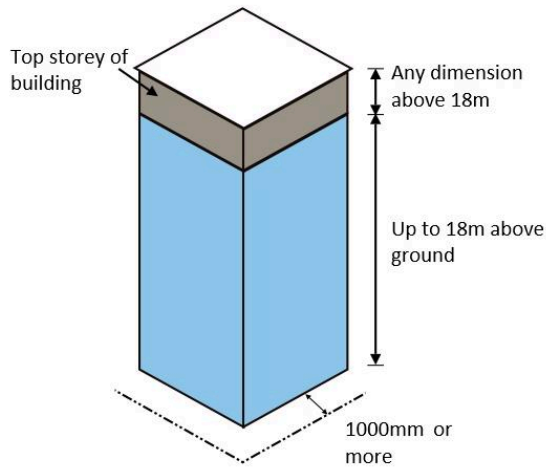

Any other building less than 18m

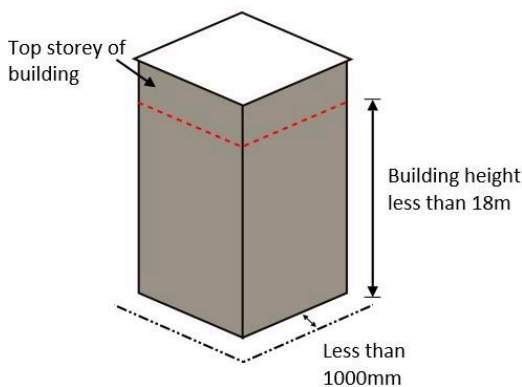

Any other building less than 18m

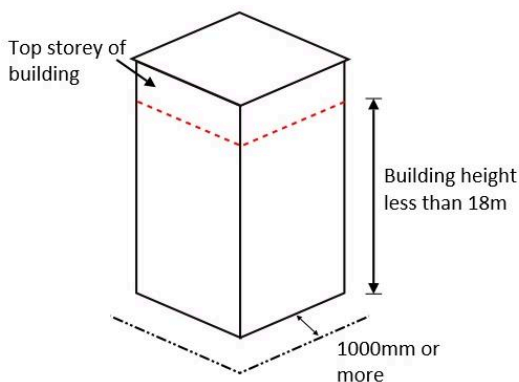

**Purpose Groups 1 and 2
11m or less**

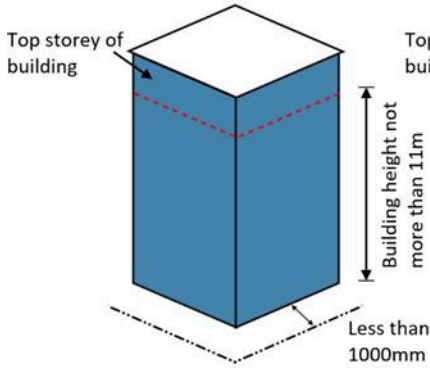

**Purpose Groups 1 and 2
11m or less**

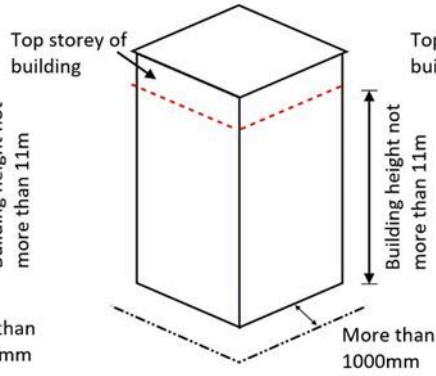

**Purpose Groups 1 and 2
greater than 11m**

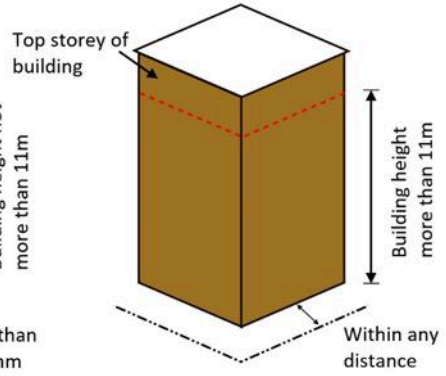

Assembly & recreational building 18m or less, and more than 1000mm from the relevant boundary

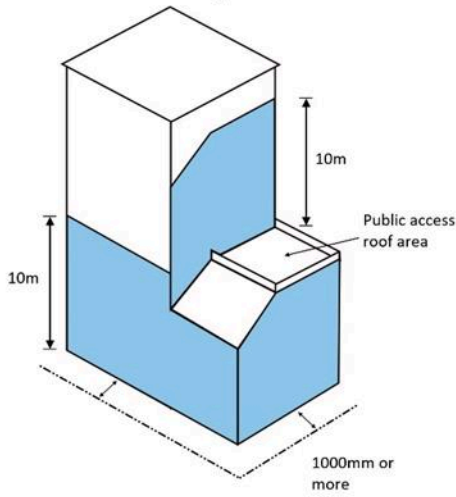

Assembly & recreational building 18m or less and less than 1000mm from the relevant boundary

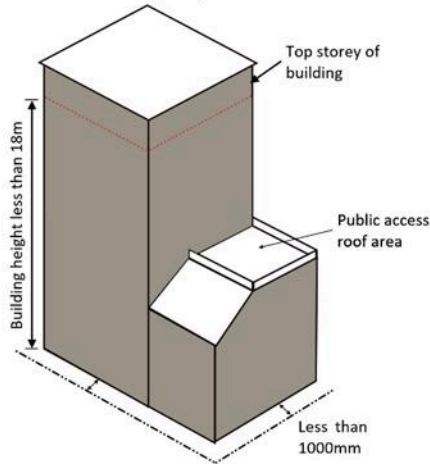

Assembly & recreational building more than 18m and more than 1000mm from the relevant boundary

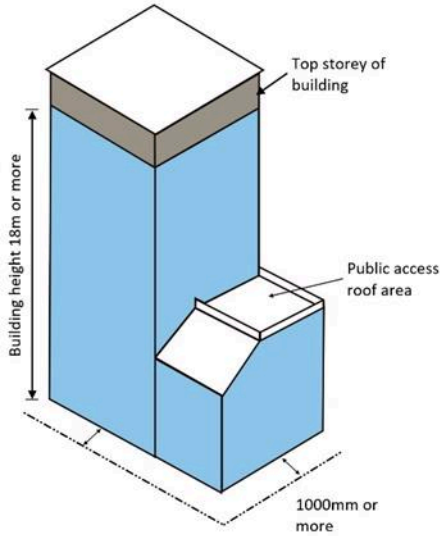

Assembly & recreational building more than 18m and less than 1000mm from the relevant boundary

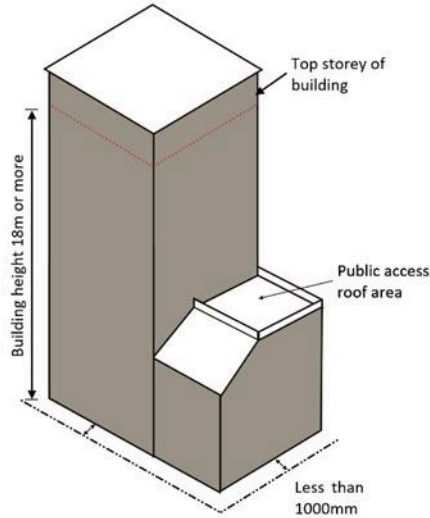

Scotland

The Technical Standards classifies each building type into a purpose group and details the minimum Euroclassification requirements to EN 13501-1 for the Reaction to Fire performance of external surface of walls. This is broken down against building height and proximity to the site boundary. An overview can be seen in the table below and considered to be the linear route for compliance.

Table 5			
Reaction to fire performance of external surface of walls			
Building use	Topmost storey heights above ground	Less than 1m from the relevant boundary	1m or more from the relevant boundary
Residential including single storey housing, any height		A1 or A2 ⁽¹⁾	A1 or A2 ⁽¹⁾
Entertainment and assembly building	Any	A1 or A2	A1 or A2
Entertainment and assembly building with a total storey area not more than 500m ²	11m	A1 or A2	B, C, D or E
Hospital and residential care building	Any	A1 or A2	A1 or A2
Hospital and residential care building with a total storey area not exceeding 200m ²	11m	A1 or A2	B, C, D or E
Any other building	More than 11m	A1 or A2	A1 or A2
	Not more than 11m	A1 or A2	B, C, D or E

(1) External wall cladding not more than 1m from a boundary should achieve European Classification A1 or A2 except cladding to a house where:

- the cladding achieves a European Classification B, and
- the wall behind the cladding has the appropriate fire resistance duration from both sides.

Where the building has a storey at a height of more than 11m above the ground, it must either follow the linear route where the external wall cladding system should be constructed of products achieving European Classification A1 or A2.





Alternatively, a non-linear route may be adopted by using the alternative guidance within the Technical Standards. This consists of demonstrating compliance to BR 135 'Fire Performance of external thermal insulation for walls of multistorey buildings and BS 8414-1 or BS 8414-2. At the time of writing, interim guidance on the alternative route, places a requirement on the building designers to notify Building Standards Division of any building warrant applications made citing the BS 8414 as a route to compliance.

Specified attachments

There is a risk of vertical fire spread from specified attachments to an external wall including balconies, solar panels, and solar shading. Solar shading are devices attached to an external wall to reduce heat gain within a building by deflecting sunlight. Fire-fighters may not be able to apply a water jet from a fire-fighting hose directly onto a fire that has spread onto specified attachments high above the ground.

Where the building has a storey at a height of more than 11m above the ground, specified attachments should be constructed of products achieving European Classification A1 or A2

KEY TO EXTERNAL WALL SURFACE CLASSIFICATION

-----	Relevant boundary
	A2 or better
	B or better
	C or better
	E or better
	No provision in respect to boundaries indicated

Notes:

(1) External wall cladding not more than 1m from a boundary should achieve European Classification A1 or A2 except cladding to a house where:

- the cladding achieves a European Classification B, and
- the wall behind the cladding has the appropriate fire resistance duration from both sides.

Residential including single-storey housing, any height

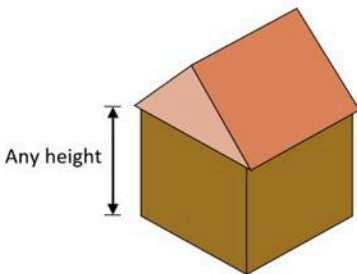

Any other building more than 11m

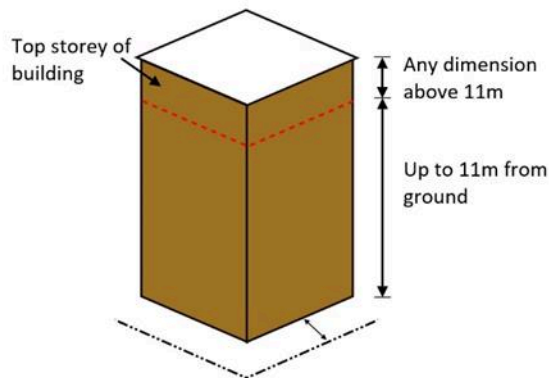

Any other building not more than 11m

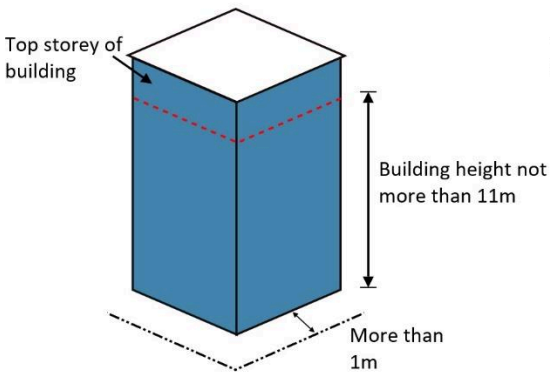

Any other building not more than 11m

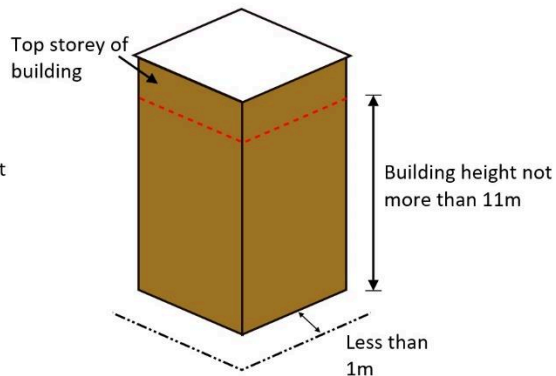

Entertainment & assembly building any height and any distance from the relevant boundary

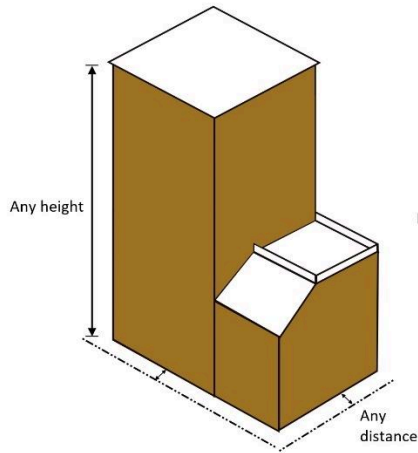

Entertainment & assembly building with a total storey area not more than 500m² 11m or less in height and less than 1m from the relevant boundary

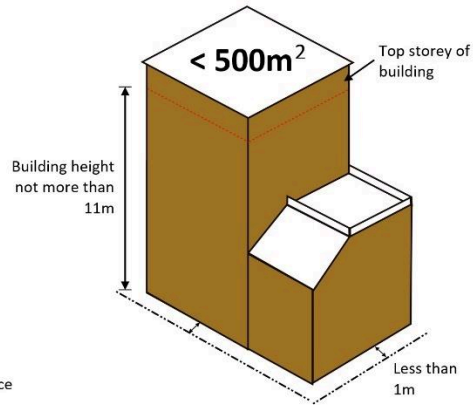

Entertainment & assembly building with a total storey area not more than 500m² 11m or less in height and more than 1m from the relevant boundary

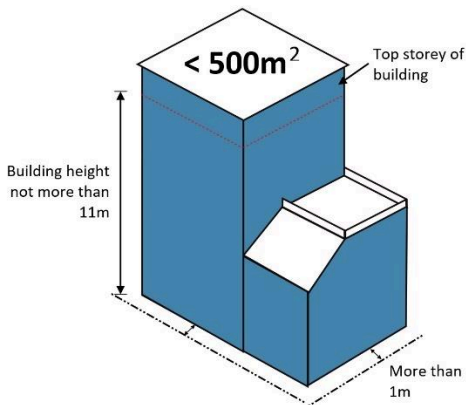

Hospital and residential care building any height and any distance from the relevant boundary

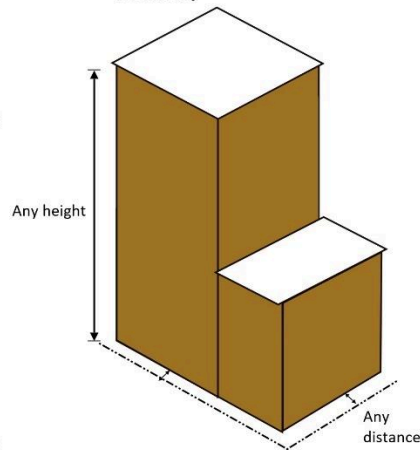

Hospital and residential care building with a total storey area not more than 200m² 11m or less in height and less than 1m distance from the relevant boundary

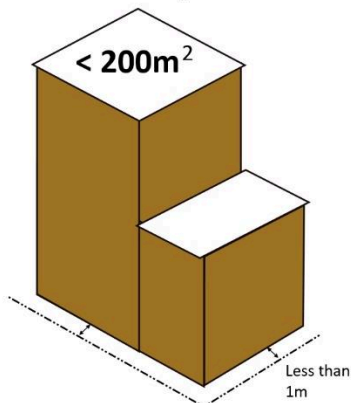

Hospital and residential care building with a total storey area not more than 200m² 11m or less in height and more than 1m distance from the relevant boundary

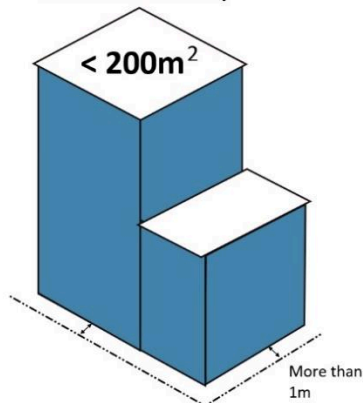

Northern Ireland

Guidance in Northern Ireland references both EN 13501-1 and the older BS 476 classifications, but only has a linear route for compliance and places all buildings under one purpose group.

The image below is taken from Technical Handbook E 2012 edition. (April 2022 AMD 7)

Table 6

Table 5.1A Reaction to fire performance of external surfaces of walls

Building Type	Building height	Less than 1 m from the relevant boundary	1 m or more from the relevant boundary
'Relevant buildings' as defined in regulation 23(4)		Class A2-s1, d0 ⁽¹⁾ or better	Class A2-s1, d0 ⁽¹⁾ or better
Assembly and recreation	More than 18 m	Class B-s3, d2 ⁽²⁾ or better	From ground level to 18 m: class C-s3, d2 ⁽³⁾ or better From 18 m in height and above: class B-s3, d2 ⁽²⁾ or better
	18 m or less	Class B-s3, d2 ⁽²⁾ or better	Up to 10 m above ground level: class C-s3, d2 ⁽³⁾ or better Up to 10 m above a roof or any part of the building to which the public have access: class C-s3, d2 ⁽³⁾ or better ⁽⁴⁾ From 10 m in height and above: Class E-d2 or better
Any other building	More than 18 m	Class B-s3, d2 ⁽²⁾ or better	From ground level to 18 m: class C-s3, d2 ⁽³⁾ or better From 18 m in height and above: class B-s3, d2 ⁽²⁾ or better
	18 m or less	Class B-s3, d2 ⁽²⁾ or better	Class E-d2 or better

Notes:

In addition to the requirements within this table, buildings with a top occupied storey above 18 m should also meet the provisions of paragraph 5.4.

(1) The restrictions for these buildings apply to all the materials used in the external wall and specified attachments (see paragraphs 5.4C to 5.4F for further guidance).

(2) Profiled or flat steel sheet at least 0.5 mm thick with an organic coating of no more than 0.2 mm thickness is also acceptable.

(3) Timber cladding at least 9 mm thick is also acceptable.

(4) 10 m is measured from the top surface of the roof.

The height of a building should be measured as shown in the diagram below.

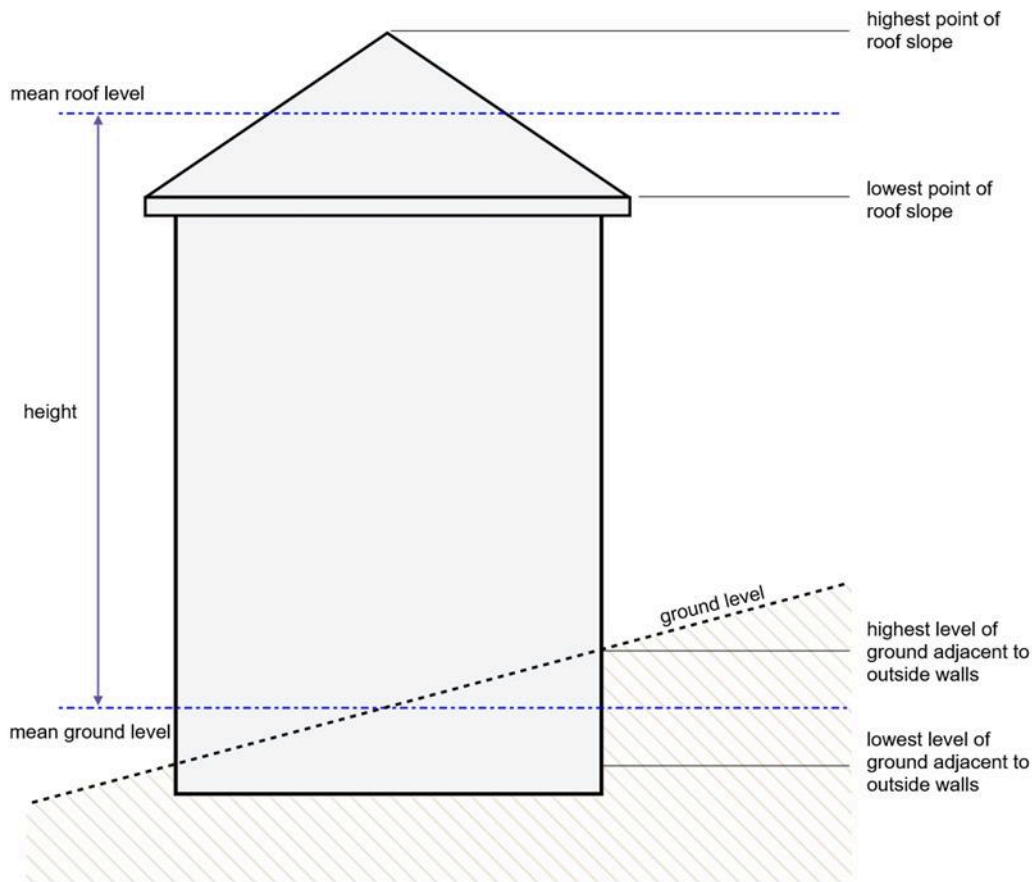

The European Classification System (Euroclass)

Whilst the Regulations and technical compliance documents have all referenced the Euroclass system for some time, they have done so in tandem with the older National British Standard series BS 476 classification system. The Euroclass system is becoming the only classification system that can now be used as compliance and in the case for many insurance companies, or third-party warranty providers, the older BS 476 system is no longer accept.

Older versions of the compliance documents referenced both the National Standards and the Euroclass, and whilst the latest versions of Approved Document B in England and Wales only reference Euroclass, it is expected that Technical Handbook 2 for Scotland and Technical Handbook E for Northern Ireland will also drop the National Standards in future editions.

The main part of the Euroclassification looks at the product or systems reaction to fire performance and classifies these as being A1, A2, B, C, D, E or F with A1 being non-combustible and F being the most combustible. In addition to the main classification, the Euroclass system has two sub classifications. The first being for smoke and is applied to Euroclasses A2 to D and classed as s1, s2 or s3. The second sub classification is for burning droplets and is applied to Euroclass A2 to E and is classed as d0, d1 or d2. Euroclass A1 and F do not have these sub classifications.

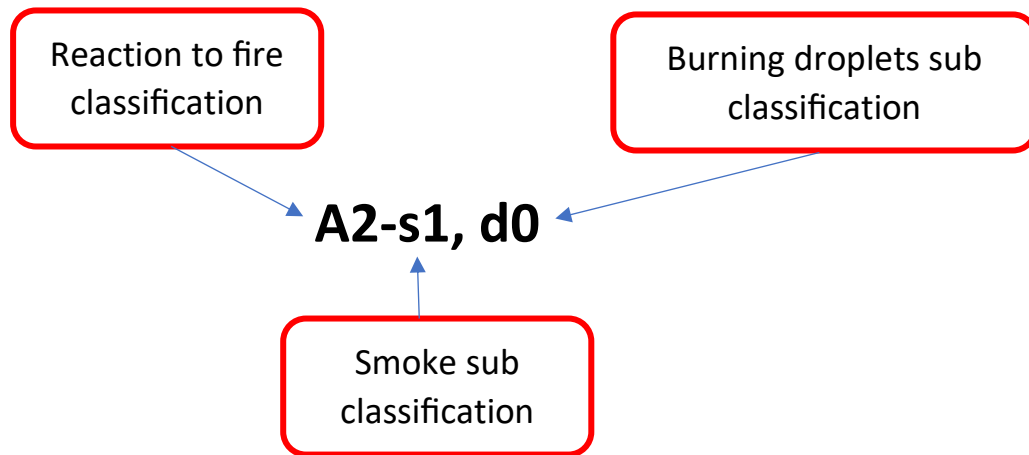

When looking at products or systems under the Euroclass system, it is important to understand how they are classified. The Euroclass system breaks products / systems down into homogenous (single material) or non-homogenous (layered or consisting of more than one product) and further breaks down non-homogenous products to identify elements that are substantial and non-substantial in relation to their impact to the fire load. A non-essential element needs to be less than 1mm in thickness and less than 1kg in area weight per m².

Layered products such as plasterboard are classified as non-homogenous products and achieve Euroclass A1 because of the plaster element, whilst the paper facing will burn. The bulk of the product is plaster but as the paper facing is less than 1mm in thickness, it is deemed to be a non-substantial layer and therefore the overall contribution to the end products fire classification is comparatively lower than the performance of the plaster core. The same criteria are applied to the testing and classification of insulated render systems as they are supplied as a complete kit of components that are built up on site to create a finished system. The product standard for these systems EAD 040083-00-0404 (replacing ETAG 004) states that the overall performance of the system should be used and not the classification of individual components.

Depending on the Euroclassification that is awarded, the method of testing to obtain the final classification differs. These are outlined within the classification standard EN 13501-1 and the table below breaks this down against each Euroclass.

Table 1 — Classes of reaction to fire performance for construction products excluding floorings and linear pipe thermal insulation products

Class	Test method(s)	Classification criteria	Additional classification
A1	EN ISO 1182 ^a	$\Delta T \leq 30$ °C; and $\Delta m \leq 50$ %; and $t_f = 0$ (i.e. no sustained flaming)	-
	and EN ISO 1716	$PCS \leq 2,0$ MJ/kg ^a and $PCS \leq 2,0$ MJ/kg ^{b c} and $PCS \leq 1,4$ MJ/m ^{2 d} and $PCS \leq 2,0$ MJ/kg ^e	-
A2	EN ISO 1182 ^a	$\Delta T \leq 50$ °C; and $\Delta m \leq 50$ %; and $t_f \leq 20$ s	-
	or EN ISO 1716	$PCS \leq 3,0$ MJ/kg ^a and $PCS \leq 4,0$ MJ/m ^{2 b} and $PCS \leq 4,0$ MJ/m ^{2 d} and $PCS \leq 3,0$ MJ/kg ^e	-
	and EN 13823	$FIGRA \leq 120$ W/s and $LFS <$ edge of specimen and $THR_{600s} \leq 7,5$ MJ	Smoke production ^f and Flaming droplets/particles ^g
B	EN 13823	$FIGRA \leq 120$ W/s and $LFS <$ edge of specimen and $THR_{600s} \leq 7,5$ MJ	Smoke production ^f and Flaming droplets/particles ^g
	and EN ISO 11925-2 ¹ : Exposure = 30 s	$F_s \leq 150$ mm within 60 s	
C	EN 13823	$FIGRA \leq 250$ W/s and $LFS <$ edge of specimen and $THR_{600s} \leq 15$ MJ	Smoke production ^f and Flaming droplets/particles ^g
	and EN ISO 11925-2 ¹ : Exposure = 30 s	$F_s \leq 150$ mm within 60 s	
D	EN 13823	$FIGRA \leq 750$ W/s	Smoke production ^f and Flaming droplets/particles ^g
	and EN ISO 11925-2 ¹ : Exposure = 30 s	$F_s \leq 150$ mm within 60 s	
E	EN ISO 11925-2 ¹ : Exposure = 15 s	$F_s \leq 150$ mm within 20 s	Flaming droplets/particles ^h
F	No performance determined		

^a For homogeneous products and substantial components of non-homogeneous products.
^b For any external non-substantial component of non-homogeneous products.
^c Alternatively, any external non-substantial component having a $PCS \leq 2,0$ MJ/m², provided that the product satisfies the following criteria of EN 13823: $FIGRA \leq 20$ W/s, and $LFS <$ edge of specimen, and $THR_{600s} \leq 4,0$ MJ, and s1, and d0.
^d For any internal non-substantial component of non-homogeneous products.
^e For the product as a whole.
^f In the last phase of the development of the test procedure, modifications of the smoke measurement system have been introduced, the effect of which needs further investigation. This may result in a modification of the limit values and/or parameters for the evaluation of the smoke production.
s1 = $SMOGRA \leq 30$ m²/s² and $TSP_{600s} \leq 50$ m²; **s2** = $SMOGRA \leq 180$ m²/s² and $TSP_{600s} \leq 200$ m²; **s3** = not s1 or s2
^g **d0** = No flaming droplets/ particles in EN 13823 within 600 s;
d1 = no flaming droplets/ particles persisting longer than 10 s in EN 13823 within 600 s;
d2 = not d0 or d1.
Ignition of the paper in EN ISO 11925-2 results in a d2 classification.
^h Pass = no ignition of the paper (no classification);
Fail = ignition of the paper (**d2** classification).
ⁱ Under conditions of surface flame attack and, if appropriate to the end-use application of the product, edge flame attack.

Fire standards

BS EN ISO 1182 Reaction to fire for products. Non-combustibility test.

This test identifies products that will not, or significantly, contribute to a fire, regardless of their end use. A sample of the product is placed in a furnace assembly which is heated, and the temperatures of the furnace and specimen are measured using thermocouples. Any sustained flaming and the weight loss of the specimen are recorded.

BS EN ISO 1716 Reaction to fire tests for products. Determination of the gross heat of combustion (calorific value).

This test determines the potential maximum total heat release of a product during the burning process, regardless of its end use. It allows the determination of both the gross heat of combustion (PCS) and the net heat of combustion (PCI). This test can also be used in accordance with ETAG 004 Annex D and EGOLF Recommendation 003-2016 to identify the worst-case configuration of system components, colours and/or textures based on the highest PCS values. By selecting and testing the worst-case configurations the results are valid for other configurations having an equivalent or better performance (i.e., lower PCS value).

BS EN ISO 11925-2 Reaction to fire tests. Ignitability of building products subjected to direct impingement of flame. Single-flame source test.

This small-scale test measures the ignitability of a product when exposed to a small flame. Specimens are tested with the flame placed on the exposed insulation edge and separately on the surface of the specimen. The specimen is exposed for 15 seconds for Class E and 30 seconds for Classes B, C and D. The test measures the time to ignition and maximum flame spread on the sample. The flame spread must not be greater than 150 mm.

BS EN 13823 Reaction to fire tests for building products. Building products excluding floorings exposed to the thermal attack by a single burning item.

The test simulates a wastepaper basket fire in the internal corner of a room. The test analyses the products of combustion to determine the Total Heat Release (THR) and Fire Growth Rate (FIGRA) for the first 10 minutes of flame exposure. A visual observation of Lateral Flame Spread (LFS) is used to determine whether flames spread across the longer wing of test specimen during the test. Measurements of the Smoke Production (TSP) and Smoke Growth Rate (SMOGRA) and observations of any flaming droplets or particles are used to determine additional classifications s1, s2 and s3 and d0, d1 and d2.

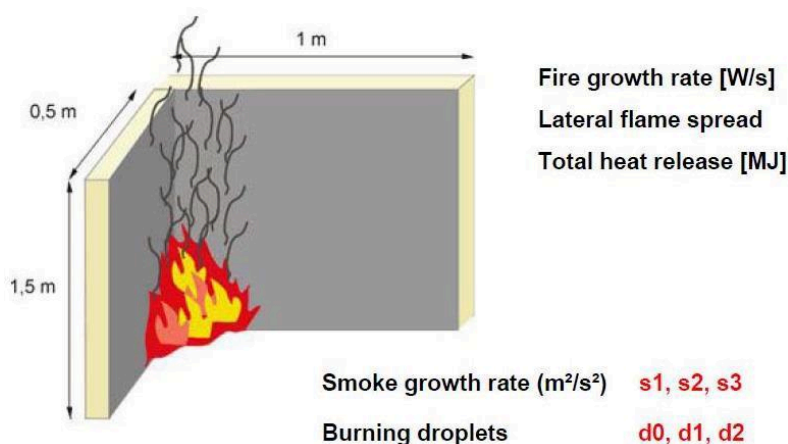

Typical example of test rig

BS EN 13501-1 Fire classification of construction products and building elements. Classification using data from reaction to fire tests.

This standard is the classification standard in which all the above test standards feed into. Depending on the results achieved and tests completed, this standard will allow you to determine the Euroclass that can be awarded to the product or system.

British Standards

BS 476-6:1989+A1:2009 - Fire tests on building materials and structures. Method of test for fire propagation for products and BS 476-7:1997 Fire tests on building materials and structures. Method of test to determine the classification of the surface spread of flame of products.

Part 6 is carried out using apparatus commonly referred to as fire propagation box and measures the amount and rate of heat released by a product under standard heating conditions. Test results are given as an Index of Performance (I) which is based on three sub- indices (i1, i2, i3). The higher the value of the Index, (I), the greater the material contribution to fire growth. The higher the value of the sub-index, i1 the greater the ease of ignition and flame spread.

Part 7 measures the spread of flame during the first minutes of test when a pilot flame is applied to the bottom corner of the specimen. The specimen is mounted in the vertical plane and placed perpendicular to a radiant heat panel for 10 minutes. Materials are classified into classes 1 to 4 in descending order of performance according to the rate and extent of flame spread over their surface under standard heating conditions.

Table 8		
Class	Flame spread at 1.5 min (mm)	Final flame spread (mm)
1	165	165
2	215	455
3	265	710
4	Exceeding Class 3 limits	

Fire Classes

The requirement for a Classes 1 to 4 is defined in the table above and are tested in accordance with BS 476-7. A Class 0 material must meet the requirements for a Class 1 and have a fire propagation index (I) of a maximum 12 and a sub-index (i1) of a maximum of 6, determined in accordance with BS 476-6:1989+A1:2009.

Although these Standards and classifications remain valid it is not accepted for inclusion on European Technical Assessments and are gradually being superseded by the more widely accepted European classification system.

BS 8414-1 Fire performance of external cladding systems. Test methods for non-loadbearing external cladding systems applied to the masonry face of a building and BS 8414-2 Fire performance of external cladding systems. Test method for non-loadbearing external cladding systems fixed to and supported by a structural steel frame.

These test methodologies allow full scale testing of EWI systems on either a solid substrate (Part 1) or a sheathed structural lightweight steel frame (Part 2). The testing procedure for each is identical with the EWI system installed on a main test wall 8 m in height, 2.6 m wide with a 1.5 m wide return wing. A 2m x 2m combustion chamber is located in the base of the main wall and a wooden crib is ignited in the chamber to simulate fire break out from a window or doorway and its propagation over the facade. Thermocouples installed through and within the EWI system at various heights on the walls constantly monitor temperature to determine external and internal fire spread over the 30minute fire duration which is followed by a 30-minute post fire observation period.



Typical examples of test rig

BR 135 (Third edition) *Fire performance of external thermal insulation for walls of multi-storey buildings*

Building Regulations refer to BR 135 “as an alternative classification to non-combustible systems written by the Building Research Establishment (BRE). It provides explanation to mechanisms of fire spread and the principles and design methodologies related to the fire spread performance characteristics of EWI systems particularly regarding fire break details within combustible systems. Additionally, Annex A and B2 provide the performance criteria and classification method for the BS 8414-1 and BS 8414 test methodology respectively. This is evaluated by analysis of the thermal couple data to determine external and internal fire spread, and visual assessment of mechanical performance, although it does not contribute to the final classification. Each classification is for the system exactly as detailed in the test report and, for example, is specific to a given thickness of insulation tested, not a thickest and thinnest range.

BS 9414 *Fire performance of external cladding systems. The application of results from BS 8414-1 and BS 8414-2 tests*

The standard provides guidelines on what variations are possible to cladding systems tested in line with the existing standards BS 8414-1 and BS 8414-2. It clarifies when systems should be subjected to a full-scale test or where the relevant results of existing test(s) can be used to understand the behaviour of the system. It does so by setting out procedures and rules with which to evaluate variations and changes to products and systems tested in accordance with BS 8414.

LPS 1581 – Issue 2.1 Requirements and tests for LPCB approval of non-load bearing cladding systems applied to the masonry face of a building and LPS 1582 - Issue 1.1 Requirements and tests for LPCB approval of non-loadbearing external cladding systems fixed to and supported by a structural steel frame.

These Loss Prevention Certification Board (LPCB) standards are nationally accredited third-party approval schemes leading to a LPCB Red Book listing. The standards allow full scale testing of EWI systems on either a solid substrate (LPS 1581), or a sheathed structural lightweight steel frame (LPS 1582). Fire testing is similar to BS 8414-1 & 2 and BR 135 classification, but with more stringent acceptance criteria for mechanical performance, burning debris and pool fires and glowing combustion (insulation). In addition to fire testing there is a full review of product documentation and specifications, combined with an annual manufacturing plant quality surveillance audit. This is required to provide a level of accreditation widely accepted by insurers. Certification is more “flexible” than BR 135 classification and for example often covers a maximum and minimum thickness range of insulation and all thicknesses in-between.

Principle insulation types and their fire performance

Stone wool, often referred to as “mineral wool”, is a mineral based fiber product, compressed and bound together with a small percentage of resin binder. It is classified as non-combustible; Euroclassification A1. It is supplied in two forms commonly referred to as slab and lamella. It is also used within EPS and Thermoset insulation systems to form non-combustible fire breaks. Generally, external wall system which incorporate mineral wool as the insulation layer have a Euroclassification of A1 or A2.

Expanded Polystyrene – generally abbreviated to EPS, is a combustible lightweight cellular plastic insulation, and very commonly specified for EWI systems. It is available in a standard white grade and recently a grey grade offering enhanced thermal resistance. When used in EWI systems the EPS must contain a flame-retardant additive and once fully enclosed in a protective layer of base coat and mesh its fire performance is greatly enhanced. Typically, EPS based systems have a Euroclassification of B or C.

Phenolic, a combustible closed cell insulation faced with a flexible tissue layer surface, has gained wide acceptance for use in EWI during recent years. It has a low flame spread and negligible smoke emission properties. Typically, phenolic foam-based systems have a Euroclassification of B or C.

Polyurethane (PUR) and Polyisocyanurate (PIR) – both classified as combustible, closed-cell, rigid foam insulation, similar in physical form, with PIR having the added advantage of improved insulating qualities and exhibiting an increased fire performance, reduced combustibility and higher working temperature limits compared to Polyurethane. Typically, PIR based systems have a Euro fire classification of B or C.

Table 9

Table indicates typical system classification when used in conjunction with the appropriate decorative finishes.

Insulation type	Generic description	Euro classification	England Wales & NI	Scotland
Mineral Wool Slab	Mineral based fibre	A1 / A2	Non-combustible or limited combustibility	Non-Combustible
Mineral Wool Lamella	Mineral based fibre	A1 / A2	Non-combustible or limited combustibility	Non-Combustible
Expanded Polystyrene (EPS) Standard (white)	Thermoplastic	B or C	Combustible	Combustible
Expanded Polystyrene (EPS) Enhanced (grey)	Thermoplastic	B or C	Combustible	Combustible
Phenolic Foam	Thermoset	B or C	Combustible	Low risk
Polyurethane (PUR)	Thermoset	B or C	Combustible	Combustible
Polyisocyanurate (PIR)	Thermoset	B or C	Combustible	Combustible

This table is aimed at providing typical full system classification of ETICS systems as designated under EN 13501-1. In all instances, confirmation must be sought by the system designer of the Reaction to Fire classification of the chosen system.

Ensure that the system selected achieves the required reaction to fire classification in accordance with EN13501, by reviewing the manufacturers test data issued by a notified body.

Key design considerations

Fire breaks, fire barriers and cavity barriers

The use of fire / cavity barriers and the location of cavity barriers remains subjective and is currently well defined within the legislative documents. The following text should be treated as guidance only and is based on the combined knowledge of the INCA Technical Committee. The use and location of these barriers should always be agreed with the project design team as part of the project design strategy and with consultation of all interested parties, including thirds party warranty providers.

The definition of fire breaks, fire barriers and cavity barriers within the insulated render and cladding industry are as follows:

Fire Breaks

Fire breaks are non-combustible elements designed to be incorporated horizontally or vertically in a non-loadbearing facade, to prevent or limit external spread of fire between floor levels, over compartment lines or from one dwelling to another.

Fire Barriers

Fire barriers are non-combustible elements designed to limit fire spread in a non-loadbearing facade, usually installed where there is a requirement to form a barrier around an opening, such as a window.

Cavity Barriers

Cavity barriers are passive fire protection elements that prevent flames and smoke from spreading via the load-bearing walls for a short period of time. They work by sealing off the gaps in a cavity during a fire and should not be confused with cavity closure which are not fire resistant.

Section 5 (B3) of Approved Document B, states the following:

Loadbearing elements of structure

Fire resistance standard

5.3 The following are excluded from the definition of 'element of structure'.

- a). A structure that supports only a roof, unless either of the following applies.
 - i. The roof performs the function of a floor, such as a roof terrace, or as a means of escape.
 - ii. The structure is essential for the stability of an external wall that needs to be fire resisting (e.g., to achieve compartmentation, or for the purposes of preventing fire spread between buildings).

b). The lowest floor of the building.

c). External walls, such as curtain walls or other forms of cladding, which transmits only self-weight and wind loads and do not transmit floor load.

Fire breaks and fire barriers

Fire spread should be contained to the floor level immediately above the origin of the fire. To achieve this in both thermoplastic insulated systems e.g., expanded polystyrene (EPS) and thermoset insulated systems e.g., phenolic foam, horizontal fire breaks should be installed at each floor level above the first-floor level i.e., starting with the second storey as stated in BR 135 section 6.3.4.

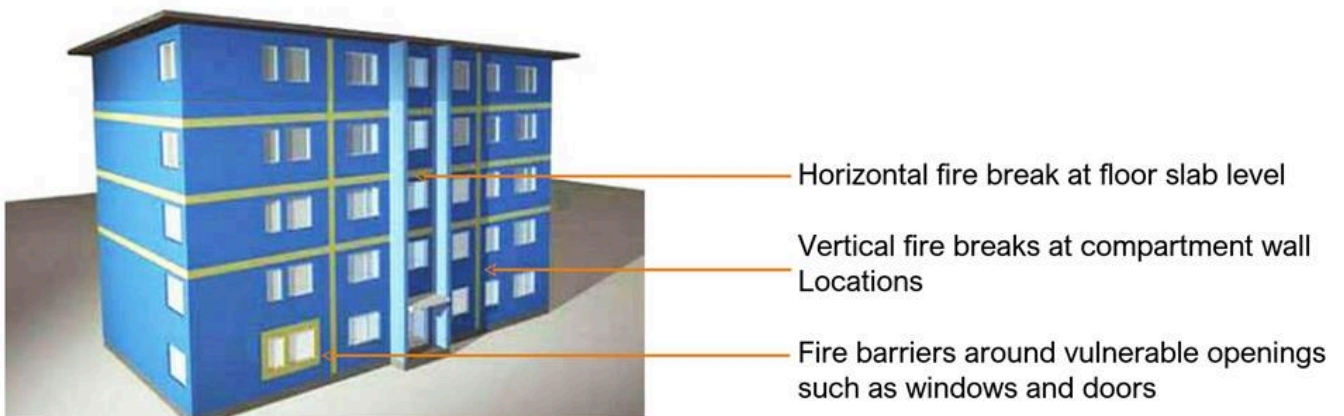

Typical example of fire break and fire barrier locations

Design principles of fire breaks and fire barriers

A typical fire break or fire barrier used with systems comprising of thermoset and thermoplastic insulation components must be constructed in non-combustible insulation material and cover the full depth of the insulation used in the system. The fire break or fire barrier, as recommended in BR 135 should be at least 100 mm high and form a continuous band through the full thickness of the insulation layer. Systems using mineral wool insulation are considered as continuous fire barriers within themselves. Systems using mineral wool insulation throughout fastened back to the substrate, if classified totally non-combustible or compliant to BR 135/LPS criteria, may be considered as continuous fire barriers in their own right.

Cavity systems (to meet NHBC requirements)

To meet the NHBC standard, EWI systems must be designed and certificated to ensure adequate in-service performance is achieved. This includes the introduction of a cavity of at least 15mm between a timber or steel framed substrate and the insulation to allow any incidental moisture the ability to naturally dry or has a free passage of drainage during normal use. In the event of fire, the installed horizontal fire breaks must have the capability of preventing fire spread through the cavity by closing it off. Many systems incorporate heat activated intumescent strips or grill systems to fulfil this requirement which is applicable to both combustible and non-combustible EWI systems. In accordance with the guidance provided in BR 135 the only effective way to assess fire performance of these types of fire barriers is to test the complete system at large scale e.g., BS 8414.

The cavity must not impede ventilation or moisture drainage during normal usage, but in the event of fire the barrier installed must have the capability of preventing fire propagation through the cavity. Special attention to detailing around vulnerable openings such as windows and doorways should be given and if required, vertical fire breaks to prevent lateral fire spread.

Fixing details

A suitable method of attaching the system to the substrate is required to ensure the system will not collapse in a fire. This can be achieved with adhesive only, adhesive supplemented by mechanical fixings, or solely mechanically fixed.

To limit the risk of the base coat layer detaching from the face of the insulation during a fire, some insurers require a stainless-steel fire fixing pin to be installed through the reinforced base coat layer at a rate of 1 per square metre, or one per insulation batt, whichever gives the greater frequency.

Stainless steel fire pins are also used to fix non-combustible fire breaks and are typically installed at 500mm maximum centres following the guidance given by the BRE.

Design approval

The location, type and fixing of all horizontal and vertical fire breaks (that may be necessary to prevent lateral fire spread) should be outlined in the design drawings as part of the fire strategy plan and agreed with the project design team and subsequently submitted to the Building Control Department for acceptance.

Compartmentation

Compartmentation stops at the line of the structure as outlined within the legislative documents. Any cavity beyond the line of compartmentation should have the fire barrier extended through the cavity and insulation layers but are not required to carry the same performance levels as the compartmentation lines. Where a cavity does not exist, i.e., the system is directly fixed to the substrate, it is good building practice to still extend these lines through the insulation layer.

Cavity barriers

A cavity barrier means any construction material provided to seal a cavity against the penetration of fire and smoke, or to restrict its movement within the cavity. In order to inhibit the spread of fire in a cavity, every cavity within a building should have cavity barriers with at least a short fire resistance duration.

Cavity barriers are tested from each side separately and should provide a minimum of both of the following:

- a. *30 minutes' integrity (E 30)*
- b. *15 minutes' insulation (I 15).*

E = Integrity. The structure's ability to not allow the passage or production of gas or vapor to the area not exposed to the fire.

I = Thermal Insulation. The ability of a structure to reduce within a temperature limit the transfer of heat to the unexposed (cold) side. The temperature limit is usually 140°C.

Every cavity barrier should be constructed to provide at least 30 minutes fire resistance and may be formed by any construction provided for another purpose if it meets the provisions set down for cavity barriers.

It is advisable to consult with a Fire Engineer regarding the suitability of the material from which a cavity barrier has been made, as the list below is specific to stud and partition walling but may be acceptable in the overall design.

Cavity barriers in a stud wall or partition, or around openings, may be formed in any of the following:

- a. Steel; minimum 0.5mm thick.
- b. Timber; minimum 38mm thick.
- c. Polythene-sleeved mineral wool, or mineral wool slab, under compression when installed in the cavity.
- d. Calcium silicate, cement-based or gypsum-based boards, minimum 12mm thick.

Cavity barriers provided around openings may be formed by the window or door frame if the frame is constructed in steel or timber of the minimum thickness in (a) or (b), as appropriate.

Cavity barriers should be tightly fitted to a rigid construction and mechanically fixed in position. If this is not possible (e.g., where a cavity barrier joins to slates, tiles, corrugated sheeting, or similar materials) the junction should be fire-stopped.

Cavity barriers should be fixed so their performance is unlikely to be made ineffective by any of the following.

- a. Movement of the building due to subsidence, shrinkage or temperature change, and movement of the external envelope due to wind.
- b. During a fire, collapse of services penetrating the cavity barriers, either by the failure of the supporting system or through degradation of the service itself (e.g., by melting or burning).
- c. During a fire, failure of the cavity barrier fixings. (In roof spaces, where cavity barriers are fixed to roof members, there is no expectation of fire resistance from roof members provided for the purpose of support.)
- d. During a fire, failure of any material or construction to which cavity barriers abut. (For example, a suspended ceiling that continues over a fire resisting wall or partition collapses, and the cavity barrier fails prematurely because the ceiling was not designed to provide a minimum fire resistance of EI 30.)

Cavity barrier locations

England and Wales

Cavity barriers should be provided at all of the following locations.

- a. At the edges of cavities, including around openings (such as windows, doors, and exit / entry points for services).
- b. At the junction between an external cavity wall and every compartment floor and compartment wall.
- c. At the junction between an internal cavity wall and every compartment floor, compartment wall or other wall or door assembly forming a fire resisting barrier.

It is not appropriate to complete a line of compartment walls by fitting cavity barriers above them. The compartment wall should be extended to the underside of the floor or roof above.

Scotland

Every cavity within a building should have cavity barriers with at least a short fire resistance duration installed around the edges of the cavity.

This includes for example, around the head, jambs and sill of an external door or window opening.

A cavity barrier should also be installed between a roof space and any other roof space, or between a cavity and any other cavity such as at the wall-head between a wall cavity and a roof space cavity.

Every cavity should be divided by cavity barriers so that the maximum distance between cavity barriers is not more than 20m where the cavity has exposed surfaces which achieve European Classification A1, A2 or B, or 10m where the cavity has exposed surfaces which achieve European Classification C, D or E.

In a building with a storey at a height of more than 11m, thermal insulation material situated or exposed within an external wall cavity, or in a cavity formed by external wall cladding, should be constructed of products which achieve European Classification A1 or A2 (see annex 2.B). However, this does not apply to insulation in a cavity that is between two leaves of masonry or concrete at least 75mm thick and the external wall is provided with cavity barriers around all openings and at the top of the wall-head.

Northern Ireland

At the junction between an external cavity wall and every compartment floor and compartment wall.

At the junction between a cavity wall and every compartment floor, compartment wall, or other wall or door assembly which forms a fire-resisting barrier.

In respect of flats only, in a protected escape route, above and below any fire-resisting construction which is not carried full storey height or (in the case of a top storey) to the underside of the roof covering.

At the edges of cavities (including around openings).

Within the void behind the external face of rainscreen cladding at every floor level, and on the line of compartment walls abutting the external wall, of buildings which have a floor more than 18 m above ground level.

Wales

Cavity barriers should be provided at the following locations:

Edges of cavities, including around openings (such as window and door openings).

Additionally, cavity barriers should be provided:

at the junction between an external cavity wall and a compartment wall that separates buildings, and at the top of such an external cavity wall,

It is important to continue any compartment wall up through a ceiling or roof cavity to maintain the standard of fire resistance – therefore compartment walls should be carried up to the roof, see paragraph 6.11. It is not appropriate to complete a line of compartment walls by fitting cavity barriers above them.

General exclusions

Cavity barriers are not necessary to divide a cavity:

- a. formed by two leaves of masonry or concrete at least 75mm thick, or
- b. in a ceiling void between a floor and a ceiling constructed in accordance with the relevant standards and clauses, or
- c. between a roof and a ceiling constructed in accordance with the guidance in the relevant standards and clauses.
- d. (Scotland) below a floor next to the ground where the cavity is either inaccessible or is not more than 1m high.

Standards summary

BS 8414-1	Fire performance of external cladding systems. Test methods for non-loadbearing external cladding systems applied to the masonry face of a building
BS 8414-2	Fire performance of external cladding systems. Test method for non-loadbearing external cladding systems fixed to and supported by a structural steel frame.
BS EN 13501-1	Fire classification of construction products and building elements. Classification using data from reaction to fire tests.
BS EN 13823	Reaction to fire tests for building products. Building products excluding floorings exposed to the thermal attack by a single burning item.
BS EN ISO 1182	Reaction to fire tests for building products. Non-combustibility test.
BS EN ISO 1716	Reaction to fire tests for building products. Determination of the gross heat of combustion (calorific value).
BS EN ISO 11925-2	Reaction to fire tests. Ignitability of building products subjected to direct impingement of flame. Single-flame source test.
BS 476-4	Fire tests on building materials and structures. Non-combustibility test for materials.
BS 476-6:1989+A1:2009	Fire tests on building materials and structures. Method of test for fire propagation for products.
BS 476-7	Fire tests on building materials and structures. Method of test to determine the classification of the surface spread of flame of products.
BS 476-11	Fire tests on building materials and structures. Method for assessing the heat emission from building materials.
BS 476-20	Fire tests on building materials and structures. Methods for determination of the fire resistance of elements of construction (general principles).
BS 476-22	Fire tests on building materials and structures. Methods for determination of the fire resistance of non-load bearing elements for construction.
BR 135 (Third edition)	Fire performance of external thermal insulation for walls of multi-storey buildings
LPS 1581 – Issue 2.1	Requirements and tests for LPCB approval of non-load bearing cladding systems applied to the masonry face of a building.
LPS 1582 - Issue 1.1	Requirements and tests for LPCB approval of non-loadbearing external cladding systems fixed to and supported by a structural steel frame.
BS 9414	Fire performance of external cladding systems. The application of results from BS 8414-1 and BS 8414-2 tests
Class 0	National Classification of fire performance referred to in Building Regulations and derived from BS 476-6:1989+A1:2009 and 7 but is not a British Standard.

Table 10 Comparison of National fire performance classifications

Equivalent European classifications and European and British Standards required to attain the respective classification

Building Regulations National classification for England and reaction To fire equivalence (1)		Building Regulation performance risk classification Scotland	Wales and N Ireland Reaction to fire equivalence European classification	European Standard test methods required to achieve classification	British Standard test methods required to achieve classification
Reaction to fire classification	BS EN 13501 classification (2)				
Non-combustible	A1	Non-Combustible	A1	BS EN ISO 1182 and BS EN ISO 1716	BS 476-4 or BS 476-11
Limited Combustibility (3)	A2-s3,d2 or better		A2-s3,d2 or better	BS EN ISO 1182 or BS EN ISO 1716 and BS EN 13823 (N/A in Scotland)	BS 476-4 or BS 476-11
Class O	B-s3,d2 or better	Low	B-s3,d2 or better	BS EN 13823 and BS EN ISO 11925-2	BS 476-6 and 7 (BS 476-7 for Scotland)
Class 1	C-s3,d2 or better	Medium	Class 1	BS EN 13823 and BS EN ISO 11925-2	BS 476-6 and 7 (BS 476-7 for Scotland)
Class 2 and 3	D-s3,d2 or better	High	Class 2 and 3	BS EN 13823 and BS EN ISO 11925-2	BS 476-6 and 7 (BS 476-7 for Scotland)
Class 4	E-s3,d2 or better	Very High	E-s3,d2 or better	A material which does not attain the performance for high risk or has no performance determined (NPD)	

- 1) National classifications do not automatically equate with the equivalent European classifications.
- 2) When a classification includes s3, d2 there is no limit set for smoke production and/or flaming droplets
- 3) When used on defined residential building over 11m in England, Wales & Scotland and 18m in Northern Ireland the system must have a European Classification of A2-s1, d0 or better

This guide is issued by INCA to give general guidance on best practice. INCA and the organisations responsible for its content do not accept any liability arising in any way from relying on this guide. If you require advice on a specific issue, you should seek your own independent professional advice.

Requests to use any part of this guide should be made in writing to:

Insulated Render and Cladding Association (INCA)
Company Number 03728766 DE73 6WU

Email: info@inca-ltd.org.uk
www.inca-ltd.org.uk